



Maxim > Design Support > Technical Documents > Application Notes > Energy Measurement & Metering > APP 5347  
Maxim > Design Support > Technical Documents > Application Notes > Powerline Communications > APP 5347

Keywords: powerline, power line, plc, powerline communications, power line communications, g3-plc, g3, ieee1901.2, DBPSK, DQPSK, D8PSK, OFDM, tunnel lighting, TLACS

APPLICATION NOTE 5347

# Powerline Communications for Street Lighting Automation

By: Scot Robertson, Executive Business Manager for Powerline Products  
Mar 27, 2012

*Abstract: This article discusses the benefits of a G3-PLC-based automation system and presents a real-world example of a system for reducing energy usage and lowering maintenance costs in tunnels. The basic system design is explained and key performance parameters discussed. A transceiver optimized for PLC automation is presented.*

A similar version of this article was published in the September/October 2011 issue of *Power Systems Design*.

## Introduction

Street lighting in its many forms—roadway lighting, tunnel lighting, car park lighting, and urban lighting—is a major consumer of electricity. All outdoor lighting is, in fact, estimated to comprise 19% of worldwide electricity usage today. For municipalities and businesses with large facilities, street lighting is a significant portion of operational expenses. Street lighting is also a vital part of public safety. Ensuring that street lights are reliably on and at the optimal illumination level for pedestrian and vehicle traffic is critical to public safety and the operators' liability. As a result, any improvements to energy usage, operational reliability, and maintenance costs provide significant payback for the organizations responsible for that street lighting. There are, of course, obvious added benefits to the environment as energy usage is lowered.

Powerline communication (PLC) is the natural choice for automating street lighting networks. PLC enables companies and municipalities to reduce operational costs and improve safety. G3-PLC is a new OFDM-based PLC system designed for grid automation that dramatically extends the range, data rate, and performance of powerline communications. This article discusses the benefits of a G3-PLC-based automation system and presents a real-world example of a system for reducing energy usage and lowering maintenance costs in tunnels. The basic system design is explained and key performance parameters discussed. A transceiver optimized for PLC automation is presented.

## PLC System Promises Benefits to the Environment and to Operators

The G3-PLC system provides a simple solution for adding communication to networks of street lights. This two-way communication enables advanced automation:

- Precision on/off times based on location, the astrological calendar, and weather conditions
- Power-saving dimming during dawn/dusk and deep night
- Traffic control through dimming
- Traffic monitoring
- Lamp failure notification
- Lamp maintenance notification based on temperature, current, PF, or operational hours
- Emergency on/off/intensity control
- Real-time monitoring of energy consumption

PLC delivers a range of advantages over wireless communication systems. Like wireless, no new wires are required. But with PLC, communication is maintained even underground, through walls, and around corners. The communication channel is owned by the operator or utility, so the risks of sharing bandwidth are eliminated. PLC has no line-of-sight limitation and is not affected by weather. Additionally, since PLC uses the powerline, it can detect when there is a line break and its approximate location.

### Tunnel Lighting: a Real-World PLC Example

The savings with PLC are seen in reduced energy usage and operational costs, which can be substantial. Consider an example of a new PLC system. The technology is currently used for tunnel lighting by Nyx Hemera Technologies. Its tunnel-lighting control system (TLACS) is delivering energy savings of 25% for fluorescent lighting and reducing maintenance cost by 30%. It greatly improves safety by matching the illumination level to the outside at the entrance and exit of tunnels.

The TLACS system is based on the OFDM PLC products from Maxim Integrated Products, which receive signals heavily attenuated by long powerlines even if the signal level is below the noise. The addressability and high data rates of Maxim's solution enable Nyx Hemera Technologies to support up to 1022 lights in a single system. The TLACS system supports wire lengths to 3km, and since it uses the powerline, is modular and easily installed on existing lighting systems (**Figure 1**).

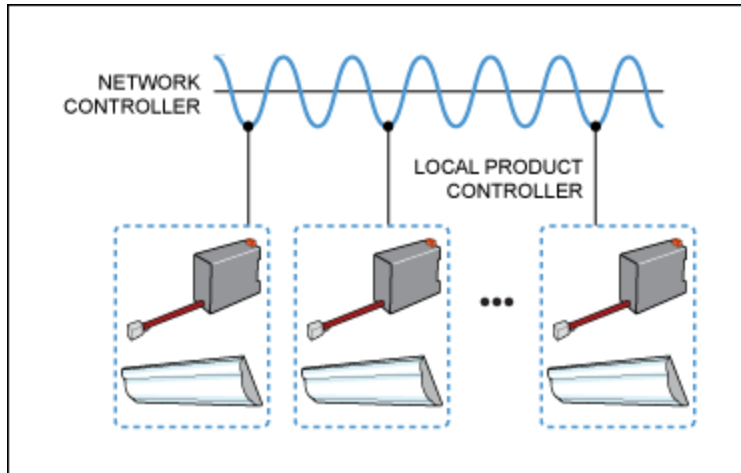

Figure 1. Scheme for PLC technology. In a TLACS system from Nyx Hemera Technologies, a local controller integrates PLC to communicate with the network controller over the AC line and controls each lamp using a standard DALI interface.

## Optimizing the Lighting Automation System

The performance and capacity of a lighting automation system are determined by the range, data rate, noise immunity, and routing capability of the PLC system.

A typical street lighting topology is illustrated below (**Figure 2**). A concentrator modem with a WAN connection, such as fiber or 2G/3G wireless, communicates with a network of modems, or nodes, which control each lamp. The range of the PLC modem determines the number of nodes with which the concentrator can directly communicate. The greater the number of nodes, the more efficient the system is.

The range of communication on a powerline is impacted by several factors: branches, which divide the power of the signal; attenuation, which varies with frequency; and interferes, such as switching power supplies, motors, and other power consumers on the line. Since noise on powerlines is dynamic (i.e., noise sources are turned on/off over time), noise immunity is crucial for the automation system to maintain its essential features. By incorporating routing capabilities in the nodes, a mesh network can be established to allow nodes connected with the concentrator to extend the network by forwarding messages to/from the concentrator and more distant nodes. Although mesh networks can greatly extend the network that a single concentrator can service, the powerline data rate determines the size which can be maintained for the desired services. Since mesh networks for street lighting have only one channel from the network to the concentrator, all of the forwarded messages must travel through one or more shared links which become the system bottleneck.

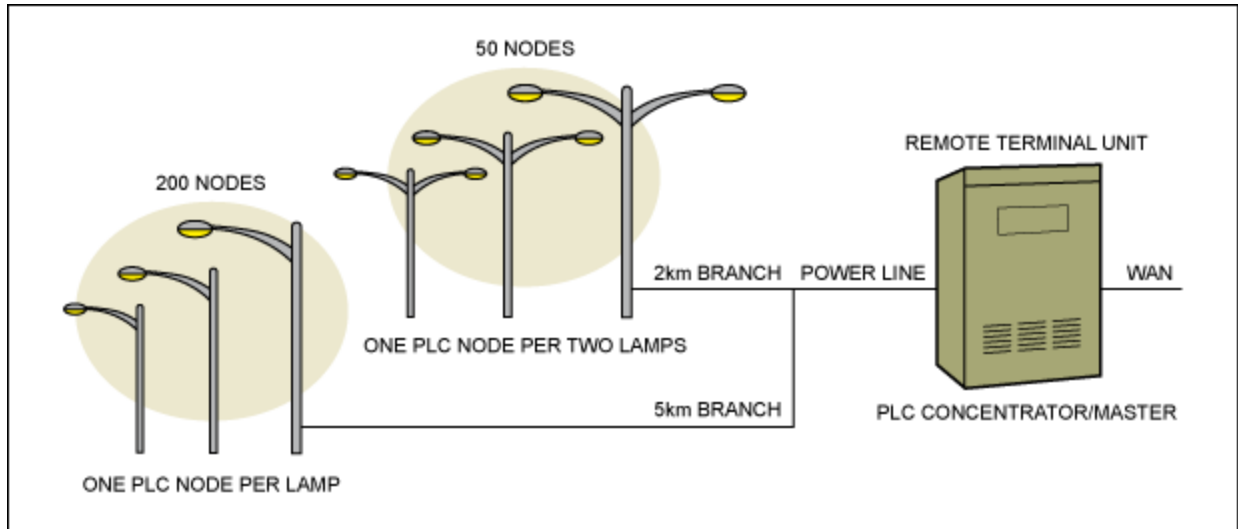

Figure 2. Example of a typical automated street-light network topology.

The [MAX2992](#) is a G3-PLC-compliant transceiver. It provides leading performance for street-light automation through advanced features that meet the PLC system's range, data rate, noise immunity, and routing requirements. The MAX2992 implements the IEEE® P1901.2 prestandard for low-frequency PLC and complies with ITU G.9955/G.9956 G3-PLC standard. Modulation using DBPSK, DQPSK, and D8PSK enable data rates up to 300kbps for the FCC band (10kHz to 487.5kHz). A robust mode maintains communication even when the signal-to-noise ratio (SNR) is -1dB. The transceiver employs dynamic link adaptation to automatically select the optimal modulation scheme and data rate based on the channel conditions. Further, adaptive tone mapping avoids interferers by selecting the sub-bands with the least noise. This, in turn, allows higher-order modulations to automatically achieve the highest data rate. An automatic association mechanism configures a mesh network when nodes are added or removed. As messages are communicated, a dynamic routing mechanism identifies and updates the best routing path across the network.

The capacity and performance of a street-lighting network are determined by the powerline topology, including the number and location of transformers, conditions on the powerline, the frequency band selected, and the message frequency. The MAX2992's data rate is up to 300kbps for the full FCC band (10kHz to 487.5kHz) when using DB8PSK modulation. The FCC band is used in the U.S. and many other countries. When communicating through powerline transformers or over long distances, the SNR is reduced due to attenuation. The MAX2992 automatically switches to DQPSK with a typical data rate of 150kbps.

The topology for the street-light network impacts the range of the communication and the mesh network configuration. Branches on the powerline both divide the PLC signal, thereby reducing the range, and create additional branches in the mesh. Additionally, management of the network is fundamental to the network's performance. Networks where nodes are polled by the concentrator have predictable message latencies; networks where each node transmits as needed are subject to contention which creates variable latencies. Topology and line conditions impact network performance significantly, so estimating the capacity and performance of a particular network is difficult. As a result, provisioning specific networks should be based on data collected in trials using the desired message frequency and network management system.

In street-lighting applications predictable message latencies are generally preferred over variable

message latency. In this case, polling of the nodes by the concentrator is recommended. When using a round-robin polling scheme, the larger the number of nodes per concentrator, the longer the interval between messages to any one node becomes. Lighting automation such as controlling light dimming or checking traffic levels are scheduled events, allowing predictable message latencies to be compensated for in the schedule.

## Realizing the Benefits

The benefits of the G3-PLC system for large networks can be seen in the following calculation. Using G3-PLC for the FCC band of 10kHz to 490kHz, the point-to-point message time is .017 seconds during which approximately 180 bytes of payload data are transmitted. For a large network of 1000 lamps with average spacing of 80m, the total line length would be 80km.

Because of the distance or transformers which attenuate the PLC signal, the concentrator cannot communicate with each node directly. In this case, the mesh networking features of G3-PLC enable the nodes to become forwarders to route messages to/from the concentrator to each node. Seven forwarders are used in this example (**Table 1**). Using an average forwarding delay time of .005 seconds and a single concentrator which polls all nodes, the total time for the concentrator to send one message to each lamp is 10 minutes. This interval allows the operator to activate lamps or change dimming levels specific to each lamp's location (e.g., high on a hill, in an underpass, or in a valley). There is a maximum delay of 10 minutes even if all lamps must be accessed. If the same command needs to be sent to all lamps, such as an emergency "on" command, a broadcast command can be used which requires less than .2 seconds to reach all lamps.

**Table 1. Time to Poll 1000 Lamps in Mesh Network with Seven Forwarders**

Total Lamps	Forwarders	Message Time (s)	Time to Send One Message to Each Node (s)
1000	7	0.017	588 (10 min.)

## Conclusion

Street lamp manufacturers, automation integrators, and communication OEMs are developing solutions that use PLC to deploy automated street-lighting systems to conserve power, reduce maintenance costs, and provide rapid pay back to operators and the environment. The MAX2992 PLC transceiver can automatically associate, choose the best routing path, communicate through transformers, and support IPv6 networking. These optimized capabilities greatly simplify deployment of an automated street-lighting system. The device delivers leading-edge performance to enable larger networks, additional savings, and greater safety.

CENELEC is a service mark of the European Committee for Electrotechnical Standardization.

G3-PLC is a trademark of Maxim Integrated Products, Inc.

IEEE is a registered service mark of the Institute of Electrical and Electronics Engineers, Inc.

### Related Parts

<a href="#">MAX2991</a>	Power-Line Communications (PLC) Integrated Analog Front-End Transceiver	<a href="#">Free Samples</a>
<a href="#">MAX2992</a>	G3-PLC MAC/PHY Powerline Transceiver	<a href="#">Free Samples</a>

---

### More Information

For Technical Support: <http://www.maximintegrated.com/support>

For Samples: <http://www.maximintegrated.com/samples>

Other Questions and Comments: <http://www.maximintegrated.com/contact>

---

Application Note 5347: <http://www.maximintegrated.com/an5347>

APPLICATION NOTE 5347, AN5347, AN 5347, APP5347, Appnote5347, Appnote 5347

Copyright © by Maxim Integrated Products

Additional Legal Notices: <http://www.maximintegrated.com/legal>